

NOTES:

1. DIMENSIONS WITHIN THE PARENTHESES ARE METRIC UNITS (millimeters) or (Kg=Kilograms)
2. MATERIAL: FIBERGLASS REINFORCED POLYMER (FRP)
3. WEIGHT. COLUMN:
CAP:
BASE:
4. MATERIAL THICKNESS.
COLUMN: 5/8" (15.9)
5. OUTSIDE DIAMETER AT TOP OF COLUMN: 19 7/8" (504.8)
6. INSIDE DIAMETER AT TOP TOP OF COLUMN: 18 3/4" (476.3)
7. OUTSIDE DIAMETER AT BOTTOM OF COLUMN: 23 7/8" (606.4)
8. INSIDE DIAMETER AT BOTTOM OF COLUMN: 22 5/8" (574.7)
9. TAPER STARTS 119.0" (3022.6) FROM BOTTOM OF COLUMN
10. MAXIMUM LOAD BEARING LIMIT: 20000 Lbs. (9071.8 Kg)

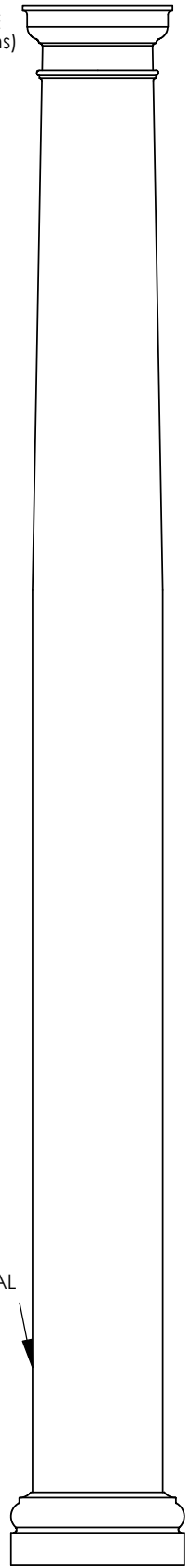
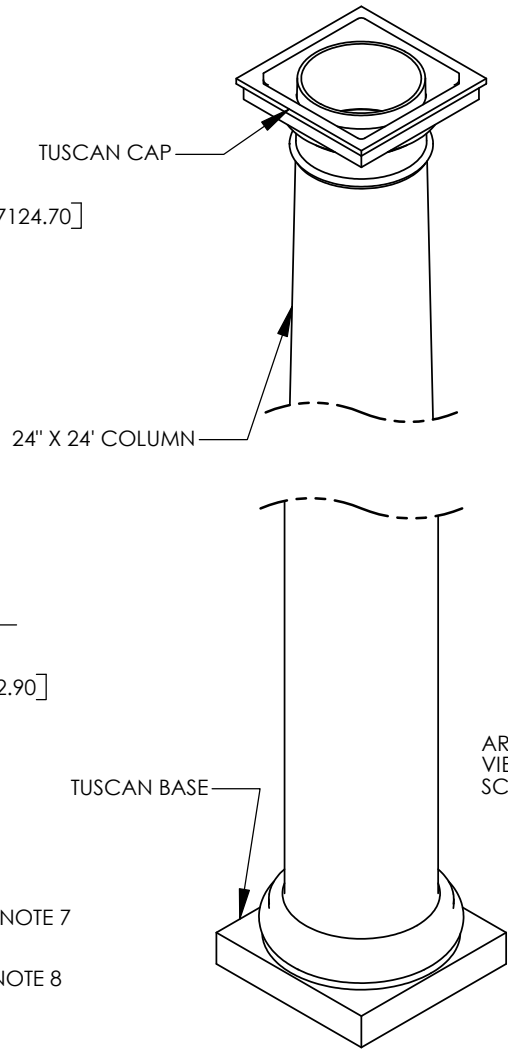
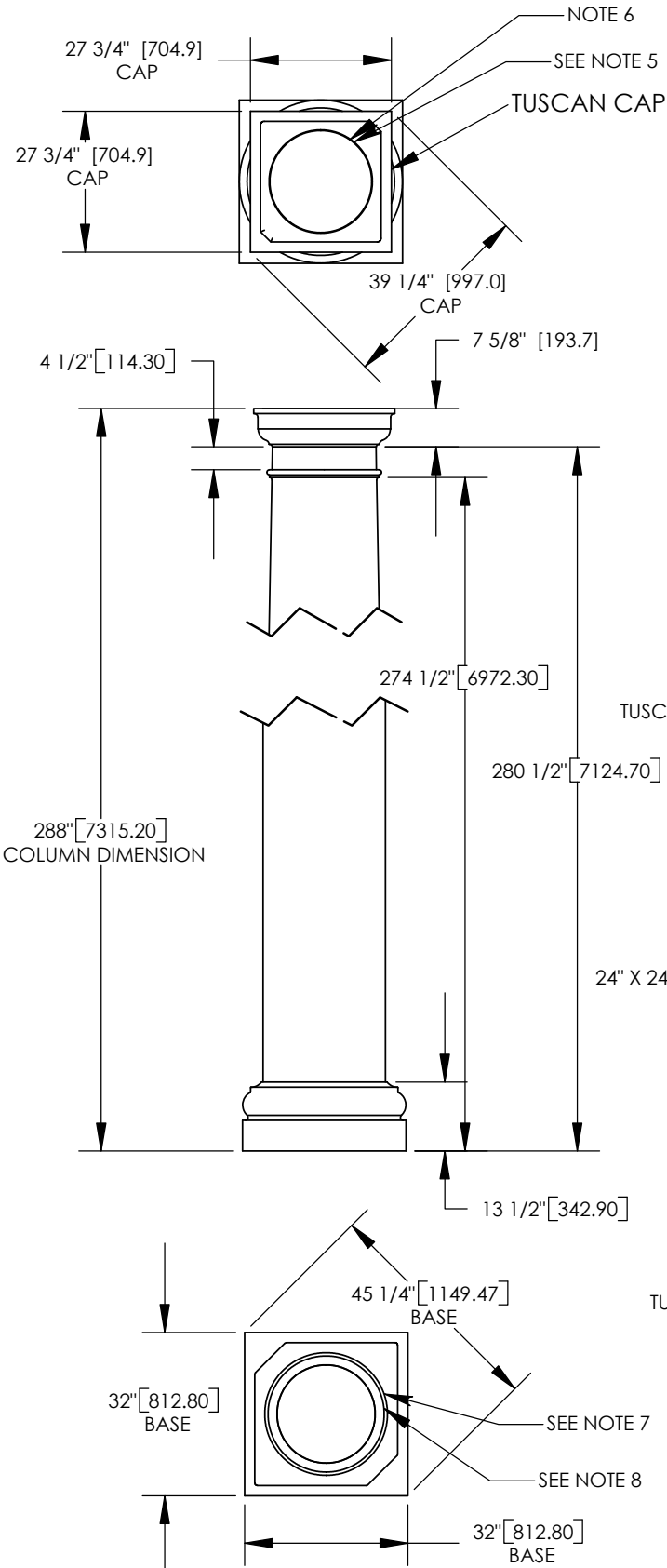

FIRST CLASS BUILDING PRODUCTS
888-514-8141

		DIMENSIONS ARE IN INCHES (mm) TOLERANCES: FRACTIONAL: ± 1/4" ANGULAR: MACH ± BEND ± TWO PLACE DECIMAL ± THREE PLACE DECIMAL ±
		MATERIAL
NEXT ASSY	USED ON	FINISH
APPLICATION		DO NOT SCALE DRAWING

	NAME	DATE
DRAWN	SOF	05/05/08
CHECKED	RK	
ENG APPR.	RK	
MFG APPR.	RK	
Q.A.	RK	
COMMENTS:		

© COPYRIGHT		
24" X 24' TUSCAN COLUMN ASSEMBLY		
SIZE	DWG. NO.	REV.
A		02
SCALE: 1/23	WEIGHT:	SHEET 1 OF 1