

NOTES:

1. DIMENSIONS WITHIN THE PARENTHESES ARE METRIC UNITS (millimeters) or ( Kg=Kilograms)
2. MATERIAL: FIBERGLASS REINFORCED POLYMER (FRP)
3. WEIGHT. COLUMN: 90 Lb. (40.8 Kg.)  
CAP: 11 Lb. (5.0 Kg.)  
BASE: 7 Lb. (3.2 Kg.)
4. MATERIAL THICKNESS.  
COLUMN: 3/8" (9.5)
5. INSIDE DIAMETER AT TOP OF COLUMN: 8 7/8 (225.4)
6. OUTSIDE DIAMETER AT TOP OF COLUMN: 9 5/8" (244.5)
7. INSIDE DIAMETER AT BOTTOM OF COLUMN: 11" (279.4)
8. OUTSIDE DIAMETER AT BOTTOM OF COLUMN: 11 3/4" (298.5)
9. TAPER STARTS 33" (838.2) FROM BOTTOM OF COLUMN.

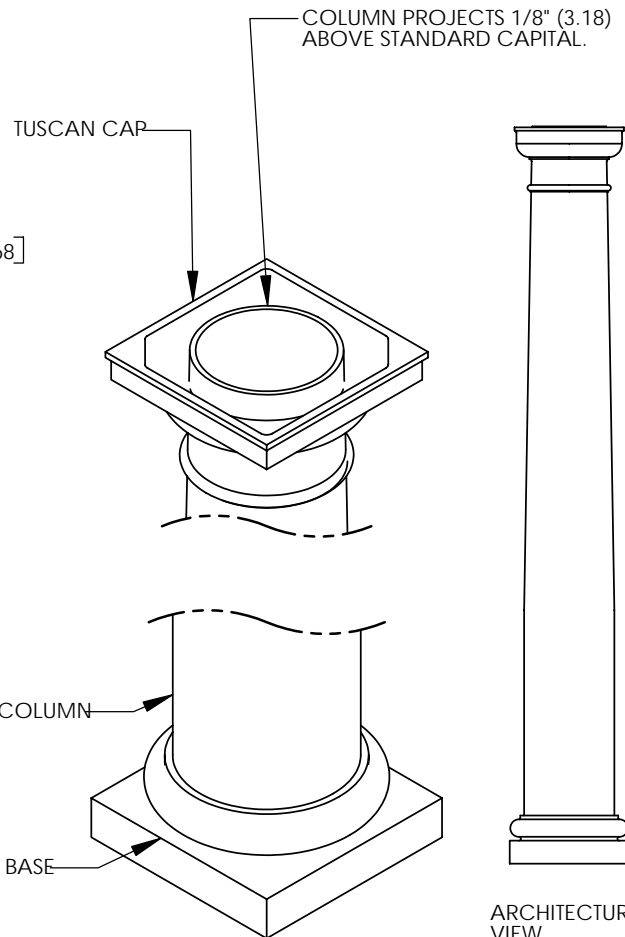
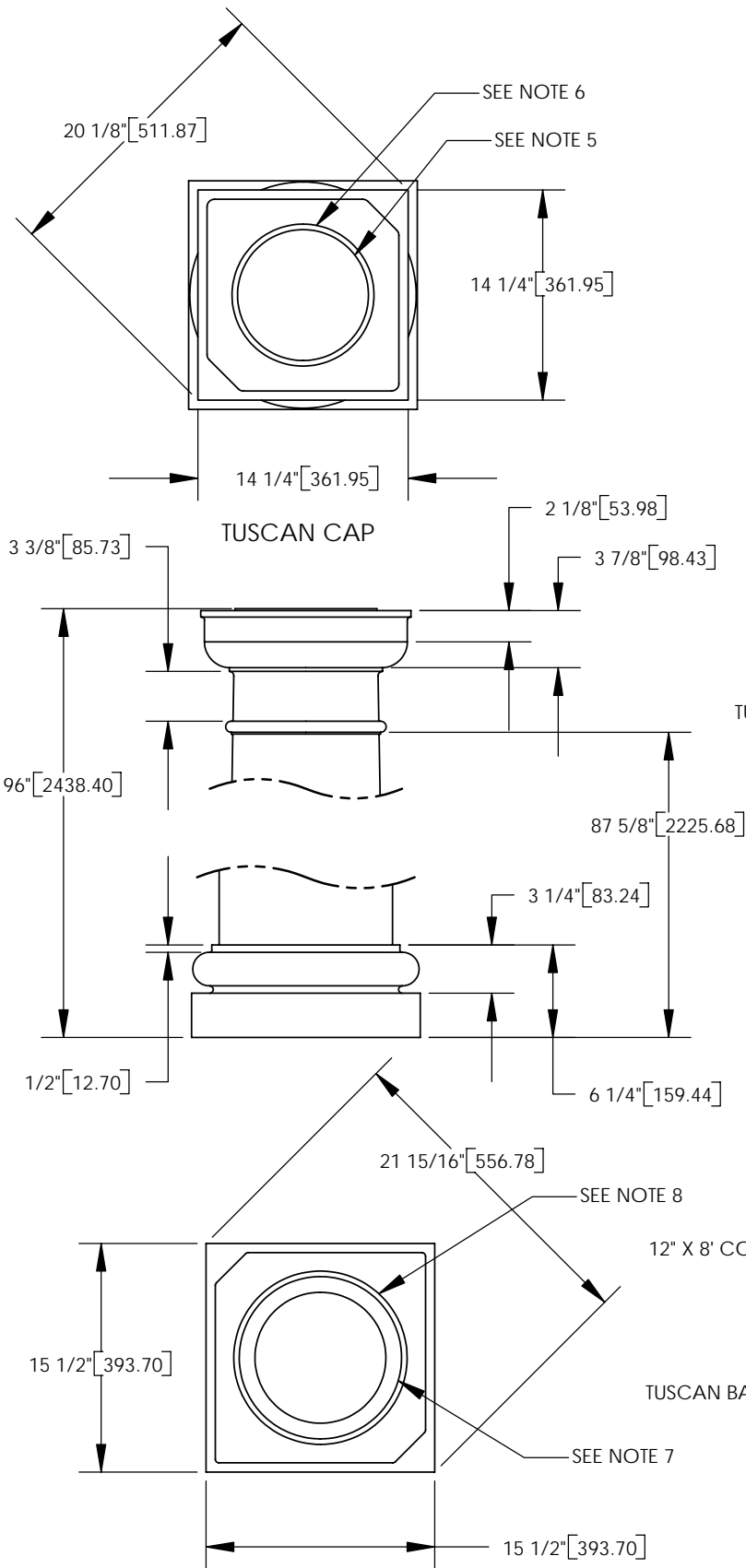

TUSCAN BASE

		DIMENSIONS ARE IN INCHES (mm)	
		TOLERANCES:	
		FRACTIONAL ± 1/8"	
		ANGULAR: MACH ±	
		BEND ±	
		TWO PLACE DECIMAL ±	
		THREE PLACE DECIMAL ±	
		MATERIAL --	
		FINISH --	
NEXT ASSY	USED ON		
APPLICATION		DO NOT SCALE DRAWING	

	NAME	DATE
DRAWN	SOF	
CHECKED		
ENG APPR.		
MFG APPR.		
Q.A.		
COMMENTS:		

© COPYRIGHT  
First Class Building Products, Inc. 2005

12" X 8' TUSCAN COLUMN  
ASSEMBLY

SIZE	DWG. NO.	REV.
A		01
SCALE: 1/12	WEIGHT:	SHEET 1 OF 1