

NOTES:

1. DIMENSIONS WITHIN THE PARENTHESES ARE METRIC UNITS (millimeters) or (Kg=Kilograms)
2. MATERIAL: FIBERGLASS REINFORCED POLYMER (FRP)
3. WEIGHT. COLUMN: 75 Lb. (34.0 Kg)  
CAP: 5 Lb. (2.3 Kg)  
BASE: 7 Lb. (3.2 Kg)
4. MATERIAL THICKNESS. COLUMN: 3/8" (9.5)
5. INSIDE DIAMETER AT TOP OF COLUMN: 5 1/2" (139.7)
6. OUTSIDE DIAMETER AT TOP OF COLUMN: 6 1/4" (158.75)
7. INSIDE DIAMETER AT BOTTOM OF COLUMN: 6 7/8" (174.6)
8. OUTSIDE DIAMETER AT BOTTOM OF COLUMN: 7 5/8" (193.65)
9. TAPER STARTS 42" (1066.8) FROM BOTTOM OF COLUMN.
10. 16 FLUTES

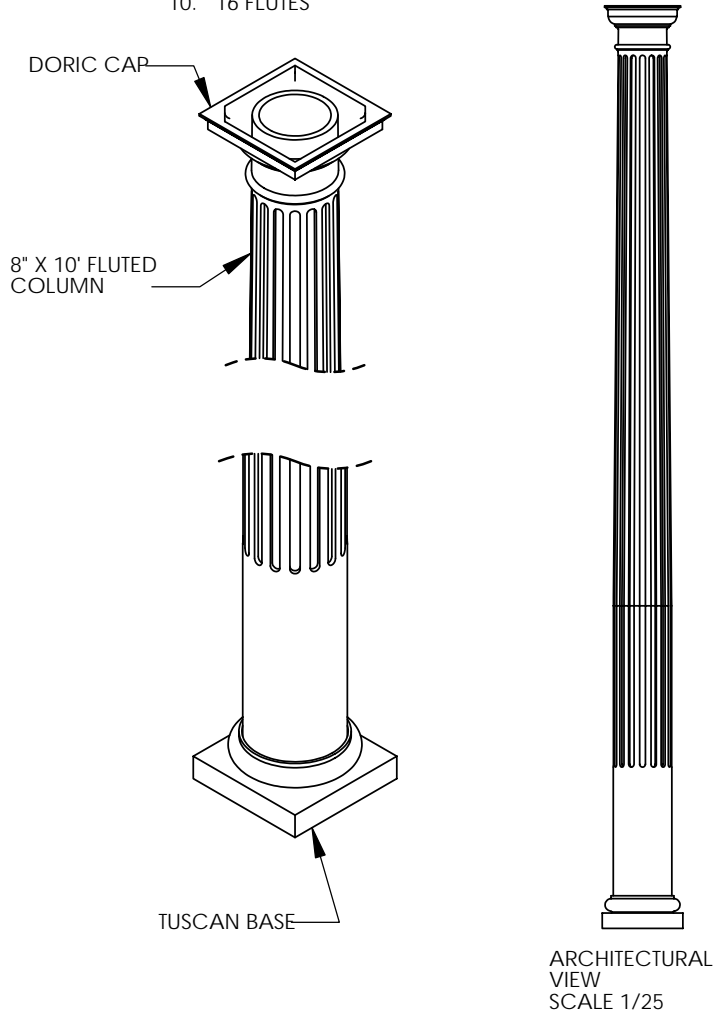
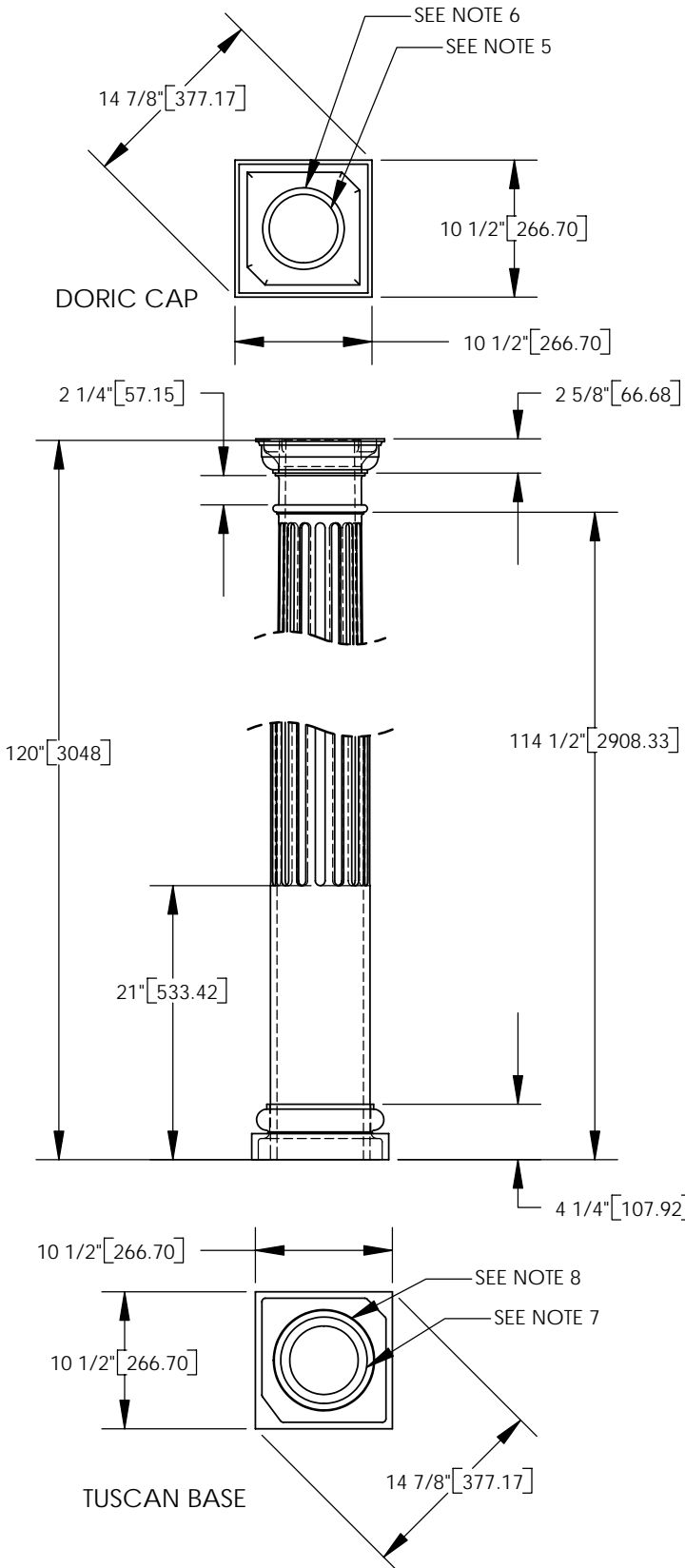

Tel: (888) 514-8141  
Fax: (770) 514-0731  
E-Mail: firstclassbp@mindspring.com

		DIMENSIONS ARE IN INCHES (mm)		NAME	DATE
		TOLERANCES:		SOF	
		FRACTIONAL ± 1/8"		CHECKED	
		ANGULAR: MACH ±		ENG APPR.	
		BEND ±		MFG APPR.	
		TWO PLACE DECIMAL ±		Q.A.	
		THREE PLACE DECIMAL ±		COMMENTS:	
		MATERIAL --			
NEXT ASSY	USED ON	FINISH --			
APPLICATION		DO NOT SCALE DRAWING			

© COPYRIGHT  
First Class Building Products, Inc. 2005

**8" X 10' FLUTED COLUMN  
W/ DORIC CAP  
& TUSCAN BASE  
ASSEMBLY**

SIZE	DWG. NO.	REV.
<b>A</b>		<b>01</b>
SCALE: 1/14	WEIGHT:	SHEET 1 OF 1