

NOTES:

1. DIMENSIONS WITHIN THE PARENTHESES ARE METRIC UNITS (millimeters) or (Kg=Kilograms)
2. MATERIAL: FIBERGLASS REINFORCED POLYMER (FRP)
3. WEIGHT. COLUMN: 50 Lb. (22.7 Kg)
CAP: 5 Lb. (2.3 Kg)
BASE: 7 Lb. (3.2 Kg)
4. MATERIAL THICKNESS. COLUMN: 3/8" (9.5)
5. INSIDE DIAMETER AT TOP OF COLUMN: 5 1/2" (139.7)
6. OUTSIDE DIAMETER AT TOP OF COLUMN: 6 1/4" (158.75)
7. INSIDE DIAMETER AT BOTTOM OF COLUMN: 6 7/8" (174.6)
8. OUTSIDE DIAMETER AT BOTTOM OF COLUMN: 7 5/8" (193.65)
9. TAPER STARTS 33" (838.2) FROM BOTTOM OF COLUMN.
10. 16 FLUTES

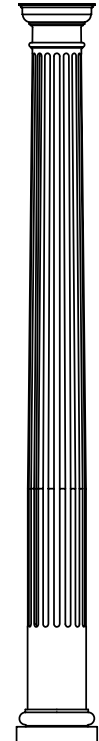
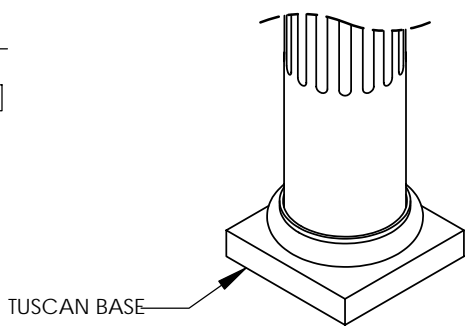
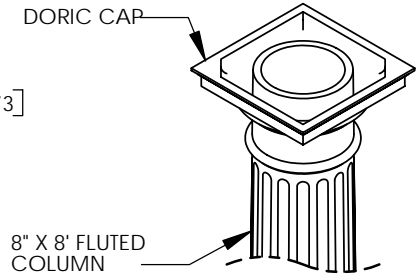
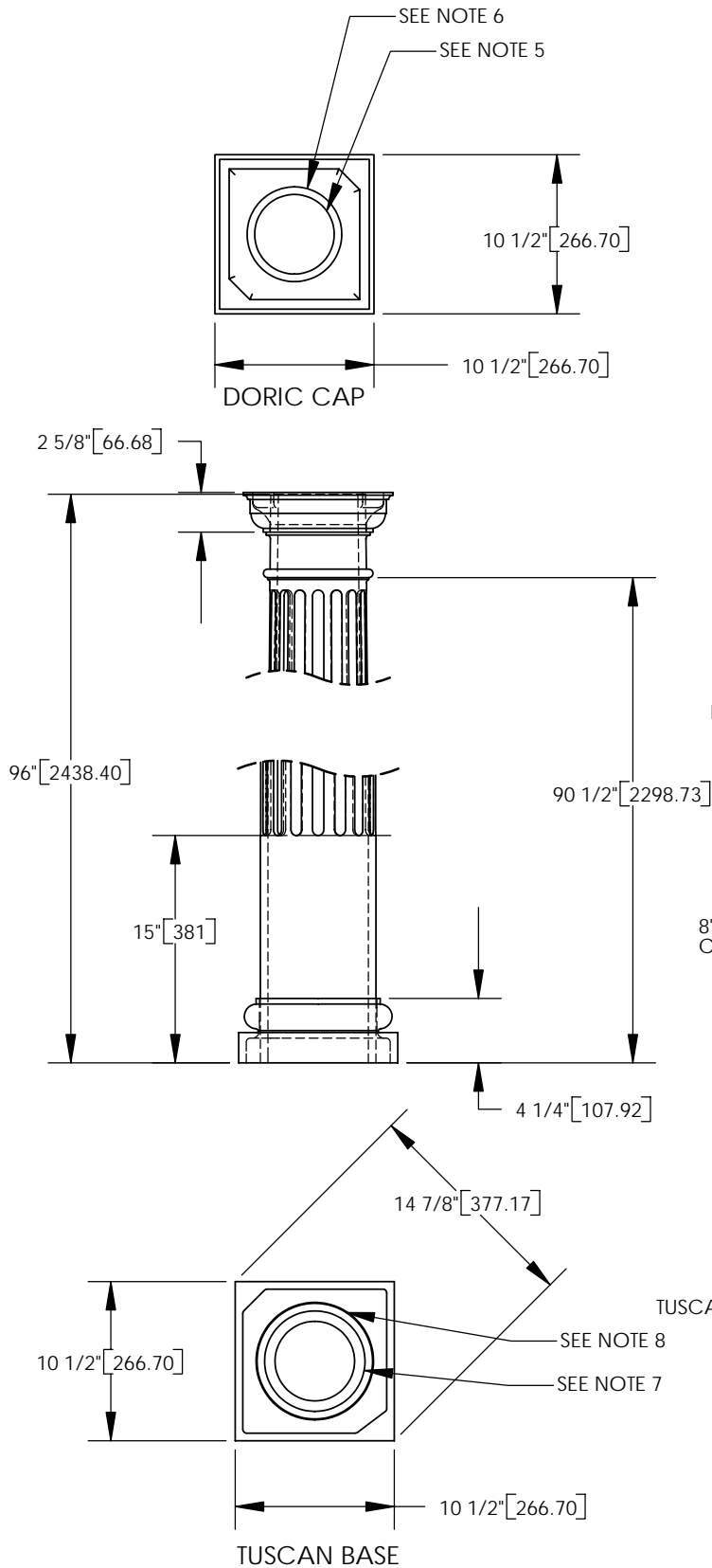

ARCHITECTURAL VIEW
SCALE 1/25

		DIMENSIONS ARE IN INCHES (mm)		NAME	DATE
		TOLERANCES: FRACTIONAL ± 1/8" ANGULAR: MACH ± BEND ± TWO PLACE DECIMAL ± THREE PLACE DECIMAL ±		DRAWN	SOF
		MATERIAL --		CHECKED	
		FINISH --		ENG APPR.	
NEXT ASSY	USED ON			MFG APPR.	
APPLICATION		DO NOT SCALE DRAWING		Q.A.	
				COMMENTS:	

© COPYRIGHT
First Class Building Products, Inc. 2005

**8" X 8' FLUTED COLUMN
W/ DORIC CAP
& TUSCAN BASE
ASSEMBLY**

SIZE	DWG. NO.	REV.
A		01
SCALE: 1/12	WEIGHT:	SHEET 1 OF 1

Tel: (888) 514-8141
Fax: (770) 514-0731
E-Mail: firstclassbp@mindspring.com